

POWERWALL

Tesla Powerwall is a fully-integrated AC battery system for residential or light commercial use. Its rechargeable lithium-ion battery pack provides energy storage for solar self-consumption, time-based control, and backup.

Powerwall's electrical interface provides a simple connection to any home or building. Its revolutionary compact design achieves market-leading energy density and is easy to install, enabling owners to quickly realize the benefits of reliable, clean power.



PERFORMANCE SPECIFICATIONS

AC Voltage (Nominal)	120/240 V
Feed-In Type	Split Phase
Grid Frequency	60 Hz
Total Energy	14 kWh ¹
Usable Energy	13.5 kWh ¹
Real Power, max continuous	5 kW (charge and discharge)
Real Power, peak (10s, off-grid/backup)	7 kW (charge and discharge)
Apparent Power, max continuous	5.8 kVA (charge and discharge)
Apparent Power, peak (10s, off-grid/backup)	7.2 kVA (charge and discharge)
Maximum Continuous Current	24 A
Maximum Output Fault Current	32 A
Overcurrent Protection Device	30 A
Load Start Capability	88 - 106 A LRA ²
Imbalance for Split-Phase Loads	100%
Power Factor Output Range	+/- 1.0 adjustable
Power Factor Range (full-rated power)	+/- 0.85
Internal Battery DC Voltage	50 V
Maximum Supply Fault Current	10 kA
Round Trip Efficiency	90% ^{1,3}
Warranty	10 years

¹Values provided for 25°C (77°F), 3.3 kW charge/discharge power.

²Load start capability may vary.

³AC to battery to AC, at beginning of life.

COMPLIANCE INFORMATION

Certifications	UL 1642, UL 1741, UL 1741 SA, UL 1741 SB, UL 1973, UL 9540, IEEE 1547-2018, UN 38.3
Grid Connection	Worldwide Compatibility
Emissions	FCC Part 15 Class B, ICES 003
Environmental	RoHS Directive 2011/65/EU
Seismic	AC156, IEEE 693-2005 (high)
Fire Testing	Meets the unit level performance criteria of UL 9540A

MECHANICAL SPECIFICATIONS

Dimensions	1150 x 753 x 147 mm (45.3 x 29.6 x 5.75 in) ⁴
Weight	114 kg (251.3 lbs) ⁴
Mounting options	Floor or wall mount

⁴Dimensions and weight differ slightly if manufactured before March 2019. Contact Tesla for additional information.

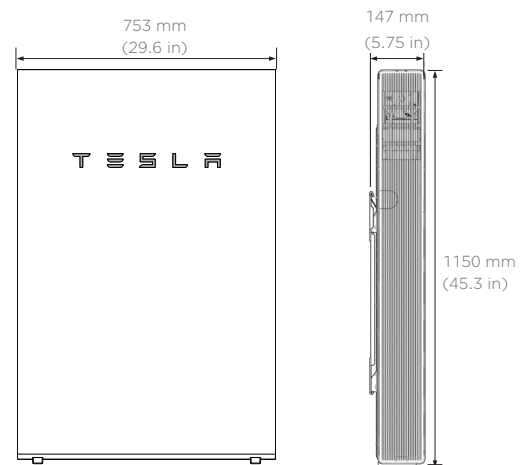

ENVIRONMENTAL SPECIFICATIONS

Operating Temperature	-20°C to 50°C (-4°F to 122°F) ⁵
Operating Humidity (RH)	Up to 100%, condensing
Storage Conditions	-20°C to 30°C (-4°F to 86°F) Up to 95% RH, non-condensing State of Energy (SoE): 25% initial
Maximum Elevation	3000 m (9843 ft)
Environment	Indoor and outdoor rated
Enclosure Type	NEMA 3R
Ingress Rating	IP67 (Battery & Power Electronics) IP56 (Wiring Compartment)
Wet Location Rating	Yes
Noise Level @ 1m	< 40 dBA at 30°C (86°F)

⁵Performance may be de-rated at operating temperatures below 10°C (50°F) or greater than 43°C (109°F).

TYPICAL SYSTEM LAYOUTS

WHOLE HOME BACKUP

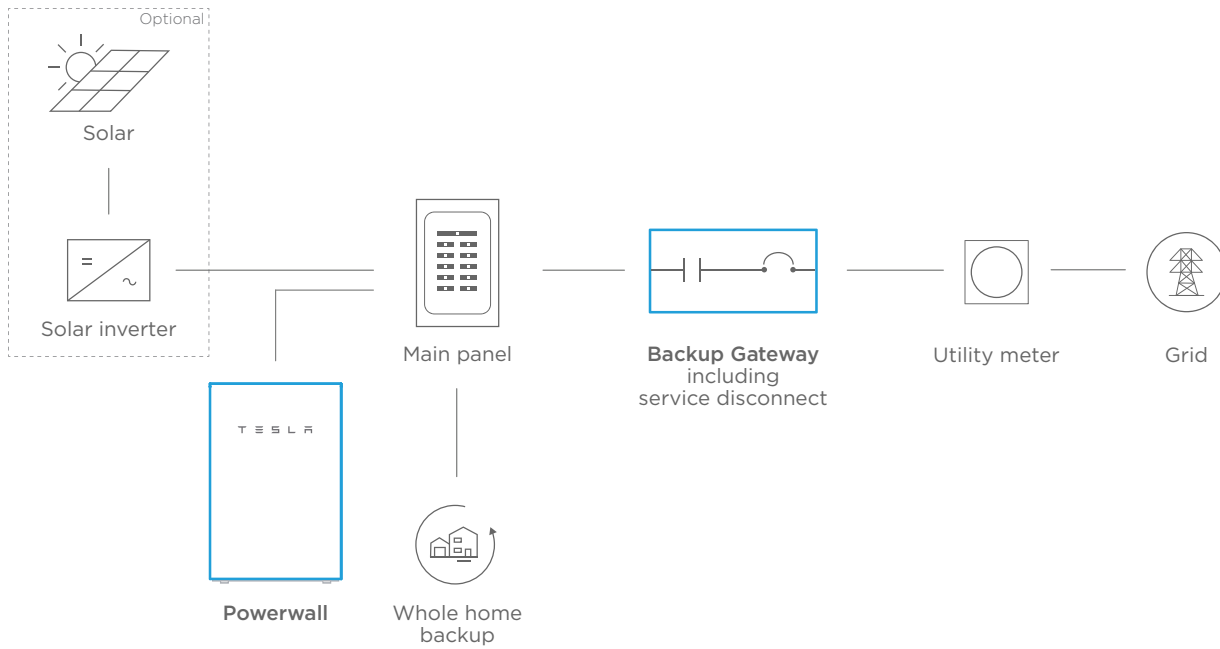

PARTIAL HOME BACKUP

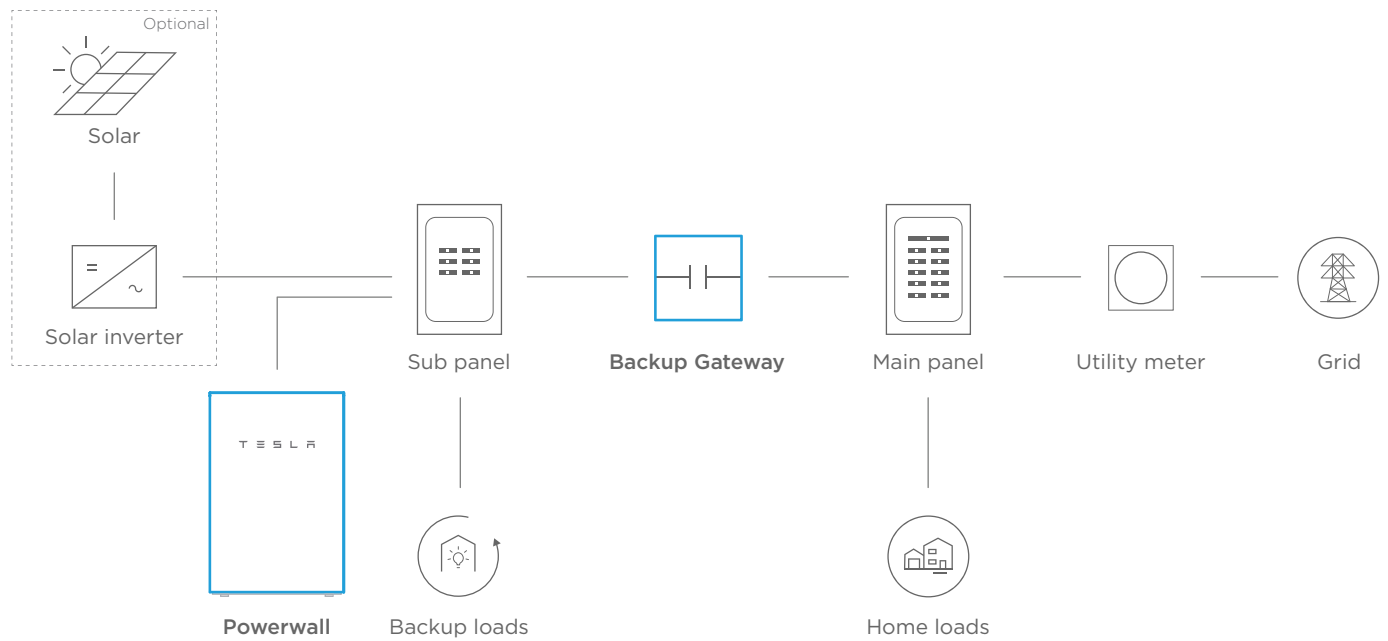



POWERWALL+

Powerwall+ is an integrated solar battery system that stores energy from solar production. Powerwall+ has two separate inverters, one for battery and one for solar, that are optimized to work together. Its integrated design and streamlined installation allow for simple connection to any home, and improved surge power capability brings whole home backup in a smaller package. Smart system controls enable owners to customize system behavior to suit their renewable energy needs.

KEY FEATURES

- Integrated battery, inverter, and system controller for a more compact install
- A suite of application modes, including self-powered, time-based control, and backup modes
- Wi-Fi, Ethernet, and LTE connectivity with easy over-the-air updates

PHOTOVOLTAIC (PV) AND BATTERY ENERGY STORAGE SYSTEM (BESS) SPECIFICATIONS

Powerwall+ Model Number	1850000-xx-y
Solar Assembly Model Number	1538000-xx-y
Nominal Battery Energy	13.5 kWh
Nominal Grid Voltage (Input / Output)	120/240 VAC
Grid Voltage Range	211.2 - 264 VAC
Frequency	60 Hz
Phase	240 VAC: 2W+N+GND
Maximum Continuous Power On-Grid	7.6 kVA full sun / 5.8 kVA no sun ¹
Maximum Continuous Power Off-Grid	9.6 kW full sun / 7 kW no sun ¹
Peak Off-Grid Power (10 s)	22 kW full sun / 10 kW no sun ¹
Maximum Continuous Current On-Grid	32 A output
Maximum Continuous Current Off-Grid	40 A output
Load Start Capability	98 - 118 A LRA ²
PV Maximum Input Voltage	600 VDC
PV DC Input Voltage Range	60 - 550 VDC
PV DC MPPT Voltage Range	60 - 480 VDC
MPPTs	4 (or 2 combined strings)
Input Connectors per MPPT	1-2-1-2
Maximum Current per MPPT (I_{mp})	13 A (26 A for combined strings)
Maximum Short Circuit Current per MPPT (I_{sc})	15 A
Allowable DC/AC Ratio	1.7
Overcurrent Protection Device	50 A breaker
Maximum Supply Fault Current	10 kA
Output Power Factor Rating	+/- 0.9 to 1 ³
Round Trip Efficiency	90% ⁴
Solar Generation CEC Efficiency	97.5% at 208 V 98.0% at 240 V
Customer Interface	Tesla Mobile App
Internet Connectivity	Wi-Fi, Ethernet, Cellular LTE/4G ⁵
PV AC Metering	Revenue grade (+/-0.5%)
Protections	Integrated arc fault circuit interrupter (AFCI), PV Rapid Shutdown
Warranty	10 years

COMPLIANCE INFORMATION

PV Certifications	UL 1699B, UL 1741, UL 3741, UL 1741 SA, UL 1998 (US), IEEE 1547, IEEE 1547.1
Battery Energy Storage System Certifications	UL 1642, UL 1741, UL 1741 PCS, UL 1741 SA, UL 1973, UL 9540, IEEE 1547, IEEE 1547.1, UN 38.3
Grid Connection	United States
Emissions	FCC Part 15 Class B
Environmental	RoHS Directive 2011/65/EU
Seismic	AC156, IEEE 693-2005 (high)

MECHANICAL SPECIFICATIONS

Dimensions	1596 x 755 x 160 mm (62.8 x 29.7 x 6.3 in)
Total Weight	140 kg (310 lb) ⁶
Battery Assembly	118 kg (261 lb)
Solar Assembly	22 kg (49 lb)
Mounting options	Floor or wall mount

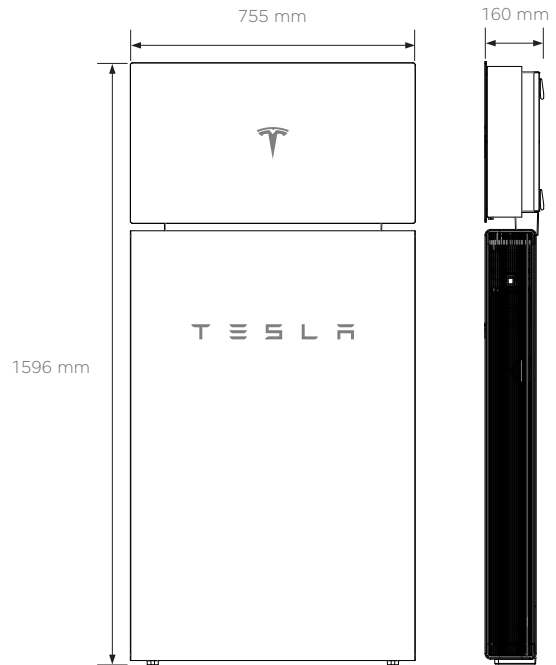

ENVIRONMENTAL SPECIFICATIONS

Operating Temperature	-20°C to 50°C (-4°F to 122°F) ⁷
Recommended Temperature	0°C to 30°C (32°F to 86°F)
Operating Humidity (RH)	Up to 100%, condensing
Storage Conditions	-20°C to 30°C (-4°F to 86°F) Up to 95% RH, non-condensing State of Energy (SoE): 25% initial
Maximum Elevation	3000 m (9843 ft)
Environment	Indoor and outdoor rated
Enclosure Type	Type 3R
Solar Assembly Ingress Rating	IP55 (Wiring Compartment)
Battery Assembly Ingress Rating	IP56 (Wiring Compartment) IP67 (Battery & Power Electronics)
Noise Level @ 1 m	< 40 db(A) optimal, < 50 db(A) maximum

¹Values provided for 25°C (77°F).

²Load start capability may vary.

³Power factor rating at max real power.

⁴AC to battery to AC, at beginning of life.

⁵Cellular connectivity subject to network service coverage and signal strength.

⁶The total weight does not include the Powerwall+ bracket, which weighs an additional 9 kg (20 lb).

⁷Performance may be de-rated at operating temperatures below 10°C (50°F) or greater than 43°C (109°F).

SOLAR SHUTDOWN DEVICE

The Tesla Solar Shutdown Device is part of the PV system rapid shutdown (RSD) function in accordance with Article 690 of the applicable NEC. When paired with Powerwall+, solar array shutdown is initiated by turning the Powerwall+ Enable switch off, or by pushing the System Shutdown Switch if one is present.

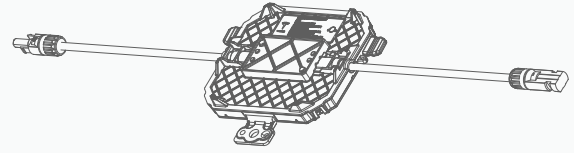

ELECTRICAL SPECIFICATIONS

Nominal Input DC Current Rating (I_{MP})	12 A
Maximum Input Short Circuit Current (I_{SC})	15 A
Maximum System Voltage	600 V DC

RSD MODULE PERFORMANCE

Maximum Number of Devices per String	5
Control	Power Line Excitation
Passive State	Normally open
Maximum Power Consumption	7 W
Warranty	25 years

COMPLIANCE INFORMATION

Certifications	UL 1741 PVRSE, UL 3741, PVRSA (Photovoltaic Rapid Shutdown Array)
RSD Initiation Method	External System Shutdown Switch
Compatible Equipment	See <i>Compatibility Table</i> below

ENVIRONMENTAL SPECIFICATIONS

Ambient Temperature	-40°C to 50°C (-40°F to 122°F)
Storage Temperature	-30°C to 60°C (-22°F to 140°F)
Enclosure Rating	NEMA 4 / IP65

MECHANICAL SPECIFICATIONS

Electrical Connections	MC4 Connector
Housing	Plastic
Dimensions	125 mm x 150 mm x 22 mm (5 in x 6 in x 1 in)
Weight	350 g (0.77 lb)
Mounting Options	ZEP Home Run Clip M4 Screw (#10) M8 Bolt (5/16") Nail / Wood screw

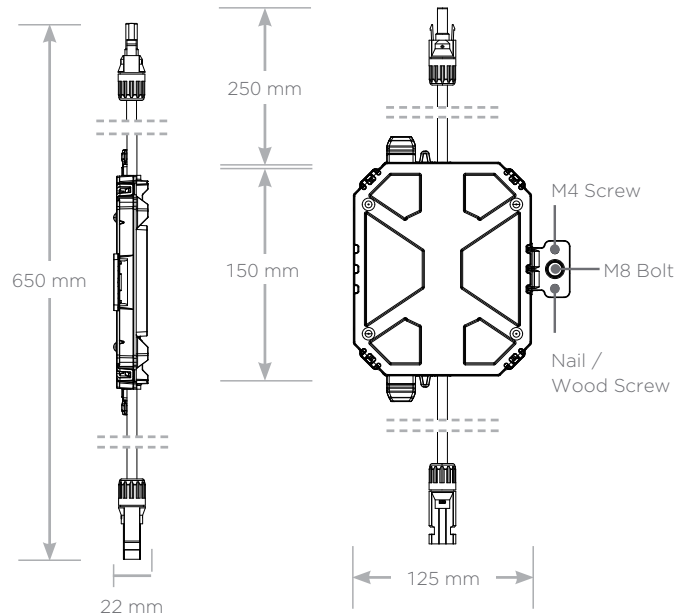

UL 3741 PV HAZARD CONTROL (AND PVRSA) COMPATIBILITY

Tesla Solar Roof and Tesla/Zep ZS Arrays using the following modules are certified to UL 3741 and UL 1741 PVRSA when installed with the Powerwall+ and Solar Shutdown Devices. See the Powerwall+ Installation Manual for detailed instructions and for guidance on installing Powerwall+ and Solar Shutdown Devices with other modules.

Brand	Model	Required Solar Shutdown Devices
Tesla	Solar Roof V3	1 Solar Shutdown Device per 10 modules
Tesla	Tesla TxxxS (where xxx = 405 to 450 W, increments of 5)	1 Solar Shutdown Device per 3 modules ¹
Tesla	Tesla TxxxH (where xxx = 395 to 415 W, increments of 5)	1 Solar Shutdown Device per 3 modules
Hanwha	Q.PEAK DUO BLK-G5	1 Solar Shutdown Device per 3 modules
Hanwha	Q.PEAK DUO BLK-G6+	1 Solar Shutdown Device per 3 modules

¹**Exception:** Tesla solar modules installed in locations where the max Voc for three modules at low design temperatures exceeds 165 V shall be limited to two modules between MCIs.

SYSTEM LAYOUTS

Powerwall+ with Backup Switch for Whole Home Backup

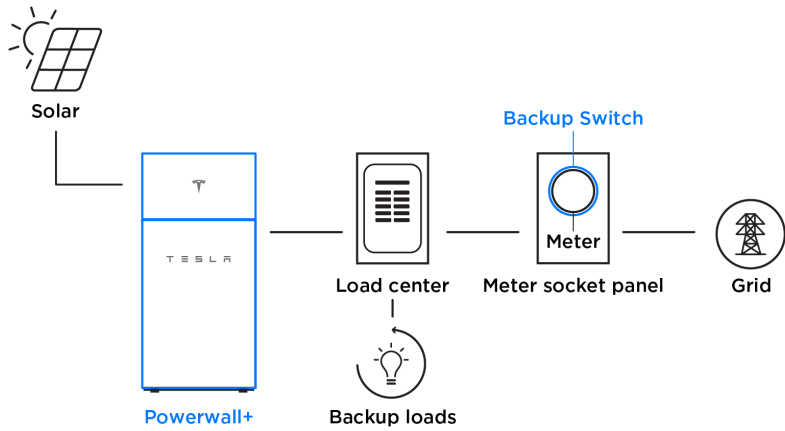

Powerwall+ with Backup Gateway 2 for Whole Home Backup

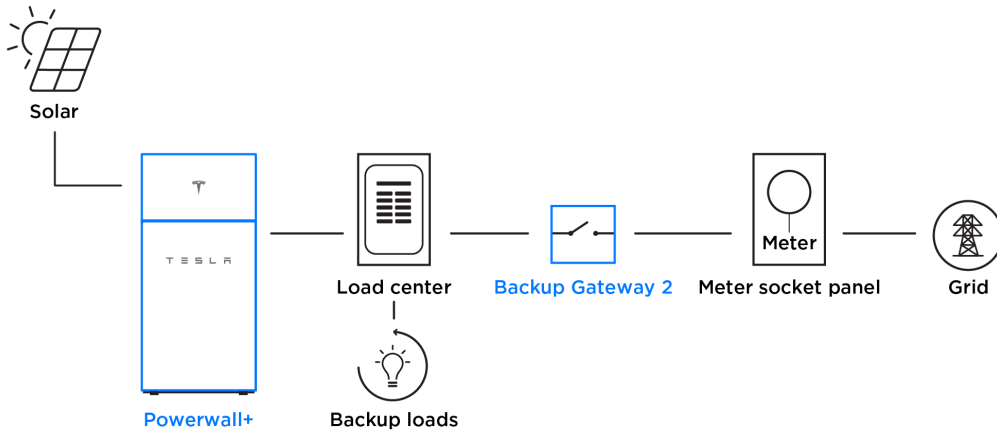

Powerwall+ with Backup Gateway 2 for Partial Home Backup

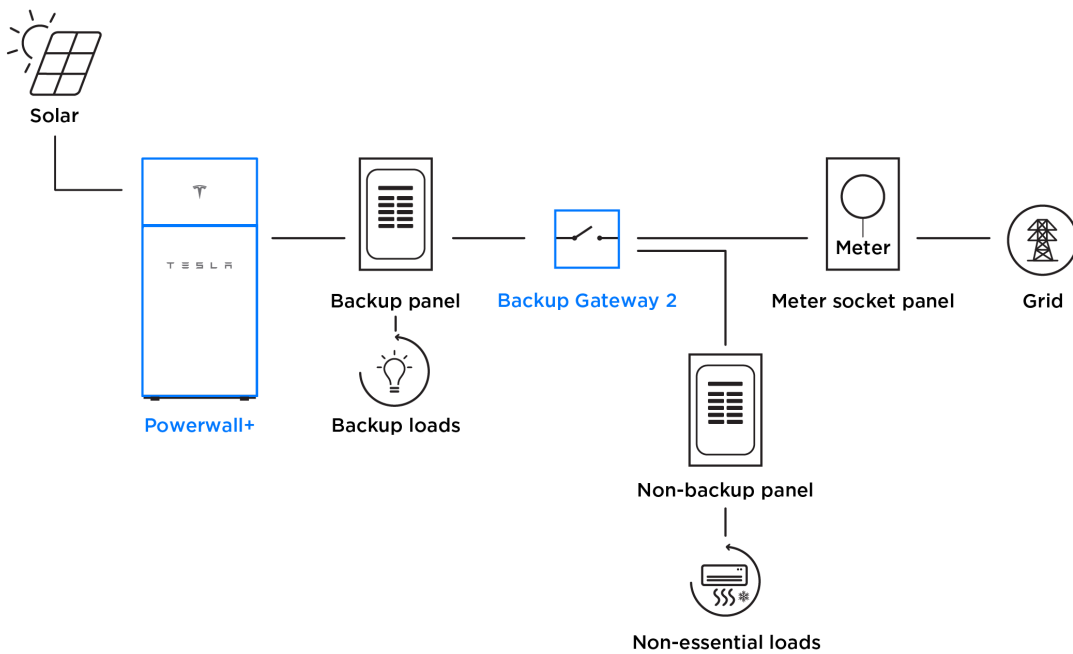

POWERWALL

Backup Gateway 2

The Backup Gateway 2 for Tesla Powerwall provides energy management and monitoring for solar self-consumption, time-based control, and backup.

The Backup Gateway 2 controls connection to the grid, automatically detecting outages and providing a seamless transition to backup power. When equipped with a main circuit breaker, the Backup Gateway 2 can be installed at the service entrance. When the optional internal panelboard is installed, the Backup Gateway 2 can also function as a load center.

The Backup Gateway 2 communicates directly with Powerwall, allowing you to monitor energy use and manage backup energy reserves from any mobile device with the Tesla app.



PERFORMANCE SPECIFICATIONS

Model Number	1232100-xx-y
AC Voltage (Nominal)	120/240V
Feed-In Type	Split Phase
Grid Frequency	60 Hz
Current Rating	200 A
Maximum Input Short Circuit Current	10 kA ¹
Overcurrent Protection Device	100-200A; Service Entrance Rated ¹
Overvoltage Category	Category IV
Internal Primary AC Meter	Revenue accurate (+/- 0.2 %)
Internal Auxiliary AC Meter	Revenue accurate (+/- 2 %)
Primary Connectivity	Ethernet, Wi-Fi
Secondary Connectivity	Cellular (3G, LTE/4G) ²
User Interface	Tesla App
Operating Modes	Support for solar self-consumption, time-based control, and backup
Backup Transition	Automatic disconnect for seamless backup
Modularity	Supports up to 10 AC-coupled Powerwalls
Optional Internal Panelboard	200A 6-space / 12 circuit breakers Siemens QP or Square D HOM breakers rated 10 - 80A or Eaton BR breakers rated 10 - 125A
Warranty	10 years

¹ When protected by Class J fuses, Backup Gateway 2 is suitable for use in circuits capable of delivering not more than 22kA symmetrical amperes.
² The customer is expected to provide internet connectivity for Backup Gateway 2; cellular should not be used as the primary mode of connectivity. Cellular connectivity subject to network operator service coverage and signal strength.

COMPLIANCE INFORMATION

Certifications	UL 67, UL 869A, UL 916, UL 1741 PCS CSA 22.2 0.19, CSA 22.2 205
Emissions	FCC Part 15, ICES 003

MECHANICAL SPECIFICATIONS

Dimensions	660 mm x 411 mm x 149 mm (26 in x 16 in x 6 in)
Weight	20.4 kg (45 lb)
Mounting options	Wall mount, Semi-flush mount

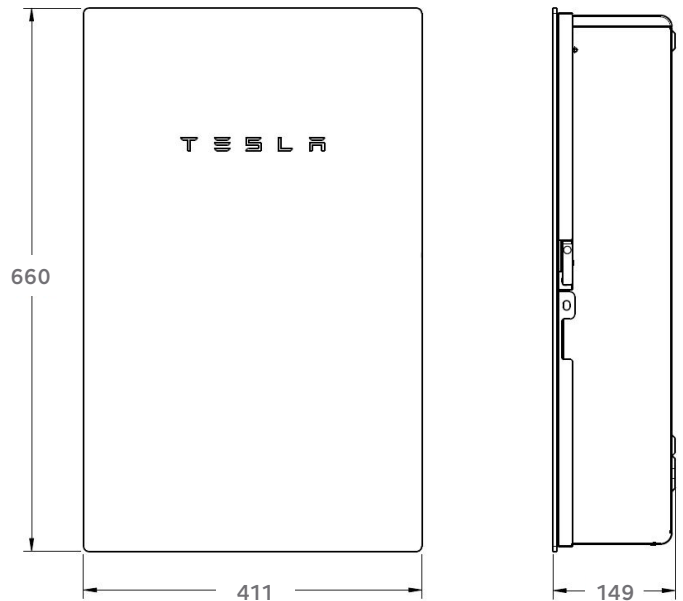

ENVIRONMENTAL SPECIFICATIONS

Operating Temperature	-20°C to 50°C (-4°F to 122°F)
Operating Humidity (RH)	Up to 100%, condensing
Maximum Elevation	3000 m (9843 ft)
Environment	Indoor and outdoor rated
Enclosure Type	NEMA 3R